UNIT 8 LIFTS AND CRANES

Structure

- 8.1 Introduction
 - Objectives
- 8.2 Basic Principles
- 8.3 Lifts (Elevators)
 - 8.3.1 Types of Lift
 - 8.3.2 Building Requirements for Lift Installation
- 8.4 Escalator
- 8.5 Lifting of Load
- 8.6 Some Basic Crane Mechanisms
- 8.7 Types of Crane
 - 8.7.1 Hand Chain Hoist
 - 8.7.2 Electric Chain Hoist
 - 8.7.3 Gantry Crane
- 8.8 Rotary Cranes or Derricks
- 8.9 Summary
- 8.10 Answers to SAQs

8.1 INTRODUCTION

Engineering marvels become visible when they are completed and are ready for use or being used. Such marvels could be tall buildings or awesome jet plane. If a building like one of Patronas towers of Kuala Lumpur being 451.7 m tall is under construction, how is material for construction is to be carried from ground level to such a great height. Same is true for other skyscrapers like Sear's Tower (443.2 m) of Chicago. The construction of Boeing Jet or Airbus Jet also poses similar problem of taking material of construction to several meters above the ground. For that matter we can think of constructing any structure be it a bridge, a building, a plane, a ship, an industrial shed – we have to move material horizontally and vertically.

The vertical moving of material remained as problem with the man for ages. Besides building tall structures man was engaged in extracting material from depth of several meters in mines.

The problem of moving materials is coupled with that of moving people in tall or even moderately tall buildings. One cannot imagine people of all age and health will be climbing the stairs to even third or fourth floor of a building. Moving people up the height has become necessity though it was earlier regarded as comfort. Rising population has compelled the city dwellers to live in multistoried buildings which now require machines like “people movers” which we call lifts or elevators. The first of its kind was made in middle of 19th century by Elisha Otis and this lift operated on steam power. Otis lifts are still the big name in the industry and lifts under this name are manufactured all over the world.

The intention of this unit is to introduce to you basic principles of design, construction and operation of load lifters which are called cranes and people movers which are called lifts.

Objectives

After studying this unit, you should be able to

- understand the basic principles of lifts and cranes,
- know what necessary requirements are to be incorporated in building for installing lift,
- know about the power requirement of these equipment,
- learn about different types of crane, their applications, and
- learn about safety and hazards in buildings.

8.2 BASIC PRINCIPLES

Both lifts and cranes are simple lifting machines. Lifts are referred to those cage like structures which move up and down along the height of a building or structure, mainly for moving people. The cranes on the other hand move material both in vertical and horizontal directions. Cranes are not the pusher or puller of goods and load in the horizontal direction on a plane but they lift and then move the load in lifted position.

Apparently both lifts and cranes perform mechanical work and the motive force is obtained from electric force in most cases though it is not a requirement. Depending upon situation, compressed air or hydraulic fluid may also provide the motive force. In fact the first lift was operated by steam.

The capacity of prime mover depends upon the work to be performed which is simply the product of the weight and the vertical distance through which the load has been lifted. One has to be careful in taking all the weights into consideration which could be combined weight of people, weight of the cage and other attachment. Another factor to consider is that after each stop the lift has to start from zero velocity and hence an accelerating force has to be created. This means a higher starting torque on prime mover. The comfort of passenger will not permit jerk at the start or stop. Almost similar conditions can be placed upon the prime mover of a crane though the comfort factor is not there. Yet a jerky start may cause the suspended load to oscillate which may pose hazard to structure, associated machinery and the prime mover itself.

For both the lifts and cranes a very important requirement is that of brakes which are required for deceleration and holding them at a particular height. In case of the lifts the holding is realized by activating the clamps between the side rails and the cage while in case of cranes brakes operate upon the main shaft of the prime movers. In both lifts and cranes the electrical connections play very important role because conducting materials are available everywhere. Hence, safety of connections is foremost. Short circuiting in case of lifts could be very dangerous and care is exercised in making electrical connections. System of warning must be incorporated in operations so that remedial action could be taken.

8.3 LIFT (ELEVATORS)

Lift or elevator is a device for moving people up and down the height of a building. The concept of lifting material from the deep mines, particularly the coal mine, seems to be much older. The method of lowering the miners was also the same and the cage was named skip. The passage connecting the surface at

which the mines used to work in horizontal tunnels was called shaft. This name has persisted in modern day building terminology for a square space left uncovered by construction and used for pipings. The earliest design of lifts or skips in the mining practice used to be a cage like structure with a flat bottom and hook at the top. The ropes which could be made in iron or steel wire would run on the grooved pulley and pulled at the other end either for lifting or lowering the skip. No side ways support was available to lift in earlier design but the later designs did incorporate the wooden columns to provide sideways supports.

Perhaps Elisha Otis was motivated by this design and produced a lift in middle of nineteenth century to be used in buildings. The basic design which still persists looked somewhat like the one shown in Figure 8.1.

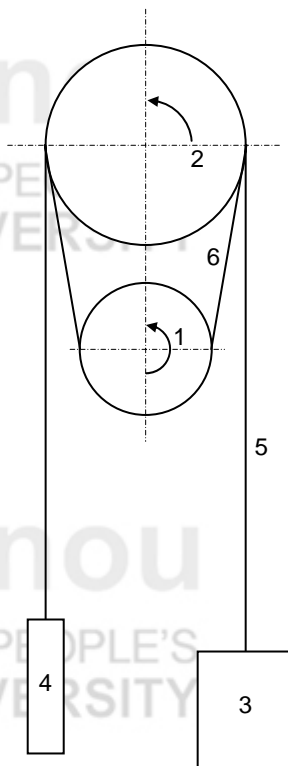

Figure 8.1 : Schematic of a Lift

Pulley 1 is the driver which receives torque from an electric motor and drives pulley 2 through belt drive. A rope drum or groove pulley is concentric with pulley 2 on which rope runs whose two sides have almost equal tension. At one end of the rope a cage, 3, or car is suspended while a balance weight, 4, is attached free at the other end.

Depending upon direction of rotation of pulley 1, the cage 3 will move up or down. The passengers can enter or leave the carriage when it stops.

The controls are provided to stop the cage at any point of ascent or descent. In practice the lift stops such that its floor is flush with the floor outside. In earlier construction there used to be two collapsible doors to open and close before one could enter the lift or leave it. One door would be fitted into wall of the building and would open in the shaft while the other would be fitted in the cage. The two would open only if they coincide in vertical plane. In present design automatically sliding doors are provided.

The lift cage normally opens to a spacious lobby on each floor of tall residential buildings. Several lifts may open to a common lobby in tall and large commercial buildings. In small buildings a single lift may open to a verandah. The lift cages are often made in form of rectangular boxes with such fittings as push button

marked with start, stop and floor numbers alongwith alarm in case a lift stops in between the floors. An exhaust fan is fitted on the roof for sucking air out, and proper lighting is provided. In large commercial buildings or small ones the lift operate in a rectangular shaft especially provided with the solid plane walls without any projections or piping along the walls. There is no view on the outside from the carriage. In several commercial buildings the lift may be placed on the outside of the façade, corner where two walls meet or on the sides. Such lift may be provided with glass walls so that occupants may look outside. Thus, the placement of a lift passage depends upon the genius of the building design, which has to agree to the requirements of the lift provider. The lift provider will design drive, the side supporting rails for the cage and slide supports for balance weight. In addition to length of the total lift passage a head room at the top of the height of about 3 m to house driving gears and electric motors is provided. This room has pair of trap doors which will open to the shaft. At the bottom a pit of depth of about half the height of the head room is provided. On the floor of the pit are fitted coil spring shock absorbers for the cage and balance weight, to absorb shock in case of free fall or to rest when not in use.

Modern lift system in a modern building is of high technology with several controls for safety and comfort, and for accuracy of operation computer controlled. A standby power supply to work automatically has also become a necessity for lift system for leaving people stranded in the shaft could be a great health hazard for some.

8.3.1 Types of Lift

As far as the purpose is concerned there is no difference between any two lifts. They perform the same function. The difference between any two arises due to height of the building. The buildings are classified in the following manner.

Low rise buildings having 2-7 floors. Medium rise buildings having 5-20 floors. High rise buildings having floors more than 15.

The lifts are designed to take same time in ascent and descent and the time should not increase unreasonably for taller buildings. For convenience and comfort, following speeds seem acceptable among the lift designer :

- For low rise building lift speed of 1 m/s.
- For medium rise building lift speed of 2 m/s.
- For high rise building lift speed of 9 m/s.

Low rise building lifts are often hydraulic jack operated. The jack is buried in the ground underneath the lift car whose platform is supported on the ram or plunger of the jack. Hydraulic power is supplied by a screw type positive displacement pump driven by an induction motor. The motor and pump are axial with pump developing a pressure of 2 to 4 MPa. The rise of the lift is arranged to be two times the displacement of ram of the jack. The electric motor may have intermittent periodic duty with starting and stopping characteristics. The motors should not have excessive temperature rise.

The medium and high rise lifts are traction motor driven which can sustain continuous operation over long period. Elaborate gear reduction drive between the motor and lift pulley shaft is provided to obtain a reduction ratio of 12 : 1 to 30 : 1.

The cabin size of the lift and hence the power of driving motor are determined by number of passengers intended to move at a time. In standard apartment building the number of passenger is between four to eight resulting in weight between 275

to 550 kgf. The lifts in large residential buildings may require to lift between 4 to 20 person in a single movement. This may result in weight between 275 to 1350 kgf. Hospital lifts may be provided with slightly greater weight carrying capacity per person. They may be designed to carry 15 to 20 person with weights between 1000 kgf to 1750 kgf.

In addition to passengers (or people) the lifts in particular cases are used for lifting only goods. In hotels, service lifts with capacity of 100 to 250 kgf are provided.

In industry, the lifts may carry freight from one floor to the other and may have weight capacity of 500 to 5000 kgf load in normal duty or of 5000 to 8000 kgf load capacity in heavy duty category.

8.3.2 Building Requirements for Lift Installation

- (a) A properly designed head room or machine room on the top of the shaft is to be provided. The floor must be able to carry the weights of electrical machines, installations, gearings, pulleys etc. The loads may be distributed as well as concentrated. The trap doors must be provided in the floor.
- (b) The machine room should have exhaust fans and rain protected windows for proper ventilation. Ambient temperature in machine room may be controlled.
- (c) Power supply of 415 V with 3 phase and MCB with 5 A 230 V single phase are required. Switches and power plugs may be specified by the lift supplier.
- (d) The size of cable will of course depend upon motor power but voltage drop of more than 20 V during motor start up is not permissible. The cable size must be chosen after due consideration of this requirement. The local codes and power supply company codes must be followed in building design and construction before the lift is installed.
- (e) As was pointed out earlier, it is not at all permitted that lift well wall be encumbered with conduits, electrical cables, protrusion etc. Only cables related to lift will be allowed to run in the shaft of the lift.
- (f) All precautions are to be taken that the lift well remains dry during all seasons and the floor of the well and inside wall are properly finished to bear reactions of side rail supports in vertical and horizontal directions.

8.4 ESCALATOR

Escalators look more impressive and complicated than lifts. Escalators are open kind of people movers and one can call them moving stairs that you take a step, you are on the stairs and just standing there you keep moving up. When you reach the top, take a step and you have climbed or moved up without actually moving your feet. Escalators are basically belt conveyors, in which the exposed part runs up an incline and takes the form of treads and riser alternately. It becomes a kind of tread mill at the beginning and end. The conveyor keeps running all the time. Horizontal versions of “escalator” are also now in use in which they just remain tread mill from beginning to end. Escalators are commonly installed at airports, hotels, railway stations etc. Figure 8.2 shows a sketch.

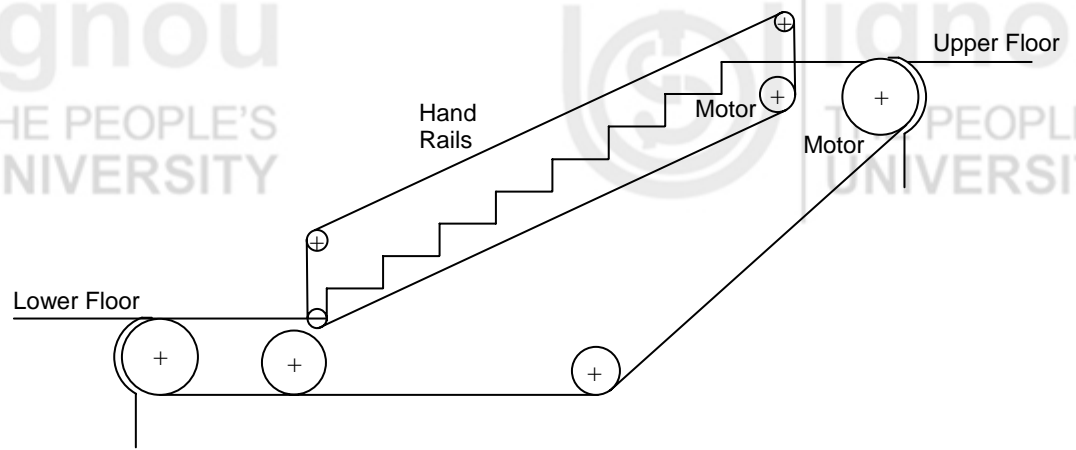

Figure 8.2 : Escalator

8.5 LIFTING OF LOAD

Human needs arise in several situations where loads need be lifted. One of the earliest triumphs of science (or call it technology) was understanding of phenomenon of load lifting. It was the search in which Archimedes was involved centuries ago and which resulted in discovering *lever*. This was a device which prompted Archimedes to declare that he could lift the earth from its orbit. Then history of mankind is replete with examples where seemingly heavy pieces of material were lifted from ground level and placed in a structure at a good height. The construction of pyramids and innumerable towers are such examples.

The principle of a heavy weight, W , lifted through a height, h , against gravity required a work, Wh , to be performed. The machine that will achieve the purpose will require certain energy input in form of a small force, E , performing work by moving certain point of machine through a distance s . Since $Es = Wh$ and $W \gg E$, $s \gg h$ which means a small effort must work over a large distance to lift a large load over a small distance. This principle of lifting machines was incorporated in earlier lifting machines so that man could apply effort with hands (which would be very small). The same principle works over now, though efforts are applied by machines and if effort to be applied is less, then the size of electric or any other machine will be small.

Based upon principle of lifting machines as illustrated above several load lifting devices have been designed and used and are still being employed. They all employ the idea of moving effort over a longer distance and load over a much smaller distance by way of a speed reduction device involving pulleys, gears, worm wheel and even levers. The motive force in the form of effort is applied by electric motor running at normal speed. Its speed is reduced through a gear drive or belt and pulley or worm and worm wheel. On the shaft of reducer a drum is mounted on which the wire rope is wound. At the end of wire rope the load is suspended through a hook. The lifted load is then moved in a straight line in which case the whole mechanism of motor and reducer has to move. The lifting machines which are called cranes are classified on the basis of how the vertical and horizontal motions are imparted to the load. Since the load lifting requirement arises in diverse places and in respect of loads of several magnitudes, shapes, size and nature, the cranes are designed both for general and specific purposes. They are fixed, or mobile in a well defined envelope, on mobile platform or mobile structure themselves. Describing all of them in a small text like this will not be possible. Therefore, a few representative cranes will be described as example. The details of design will be avoided and only principle will be in focus.

The various services obtained from cranes are cargo loading and unloading in ships and trains, construction of buildings and bridges, moving goods and materials in industry and similar.

The ratio W/E is called mechanical advantage and the ratio s/h is known as velocity ratio of the machine. The ratio of mechanical advantage to velocity ratio is defined as efficiency of the machine. The part of the energy supplied to the machine is lost in overcoming the friction between various moving parts and in overcoming the inertia of the moving parts.

8.6 SOME BASIC CRANE MECHANISMS

The principles of crane being to have large velocity ratio basic mechanisms to have greater length over which effort will move and shorter path of load have been developed. For an engineer or a scientist it will not be difficult to see that if a body placed on an inclined plane is pushed by a force, the point of application of force will move along the incline whereas the body will move up through the height. If Figure 8.3 represents the situation, inclined plane appears to be simplest kind of lifting machine. Besides use of wedges for lifting heavy loads through small heights, the principle of inclined plane is the one on which screw jacks work. The surface of a thread becomes the inclined plane while the nut becomes the sliding body.

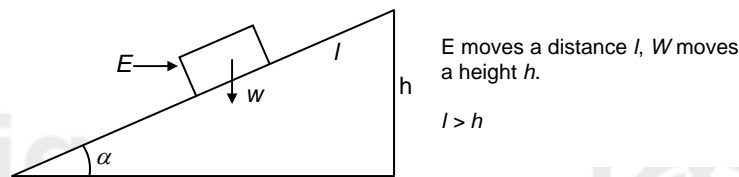

Figure 8.3 : An Inclined Plane

Combinations of pulleys, commonly known as pulley blocks, are common in industry, shop floors and construction. Two simple situations are shown in Figure 8.4. In first configuration, a mechanical advantage of 2 while in second a

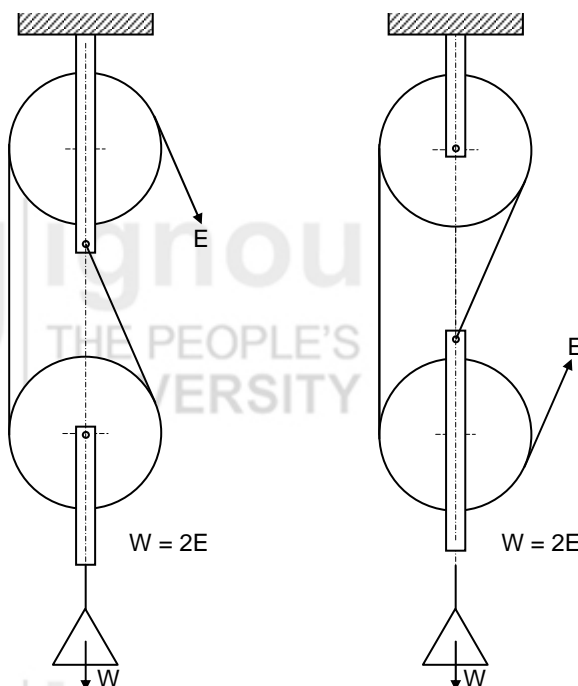

Figure 8.4 : Pulley Arrangement for Portable Hoists

mechanical advantage of 3 is obtained. By increasing number of pulleys this mechanical advantage is multiplied by number of pulleys. You must satisfy yourself by doing small calculation.

The arrangements of pulleys as shown in Figure 8.4 can also be suspended with hooks either from the roof, top of a tripod or centre of the beam of a portal frame. It can also be suspended from the trolley which traverse on overhead rails and the whole body can be shifted independently along and across the length of shed.

The other reduction units commonly used in cranes are shown in Figure 8.5. Whatever was said about the pulley blocks is also true for these arrangements but they are particularly good and suited to electric motor drives. In place of electric motor, a sprocket can be placed which can be rotated by pulling a chain passing over it.

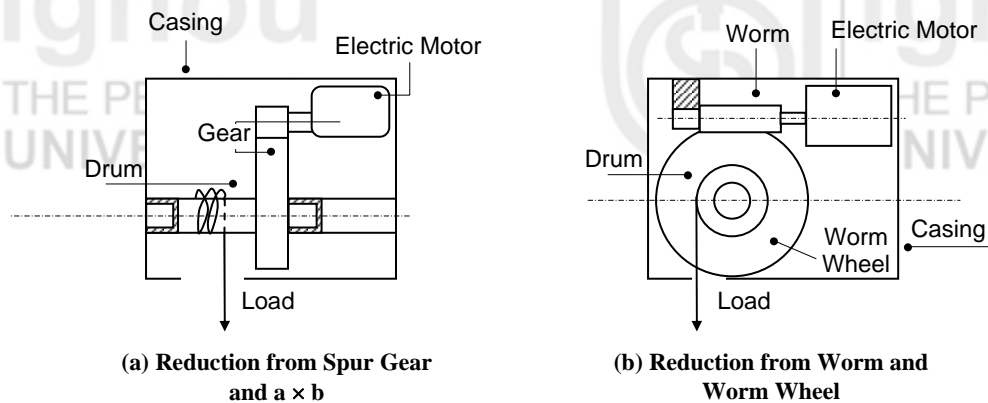

Figure 8.5

The reduction units shown are representative. By having a compound gear train the higher reduction is obtainable. The worm and worm wheel can give a reduction of speed of 100 in single stage and it is more compact. The layout and mechanical design require a great care.

8.7 TYPES OF CRANE

The cranes are not classified on the basis of the lifting mechanism but on the basis of overall structures. The type of the structure is decided depending upon the need. It may be borne in mind that the structure will carry the load as well as the weight of the mechanism and will also incorporate the motion corresponding to the movement of the load. In most cases the wire ropes or link chains carrying hook at the end are used to connect the load with the lifting mechanism. Apparently the lifting mechanism along with brake will be placed at the top. The operator may be on the ground or near the mechanism in especially designed cabin. In the following text, the description of a few commonly used cranes are taken up.

8.7.1 Hand Chain Hoist

It is a portable lifting device and carries a hook at the top of its body. The body can be hooked to a strong support in the roof or top of a tripod or a portal. An endless chain hangs out from the body of the hoist which may rotate a wheel inside. Coaxial with the wheel there may be a gear reduction unit or just an axle working as the load drum from which hangs another chain with a hook. The sketch in Figure 8.6 explains its functioning.

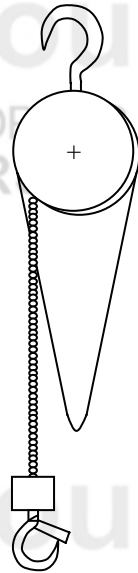

Figure 8.6 : Hand Chain Hoist

Available in different capacities from 1 T to 10 T and in different velocity ratios, e.g. effort of 21 kgf may work over a distance of 7 m or 9.8 m to lift $W = 4$ T. Effort of 43 kgf may work over a distance of 79 m or 94 m to lift $W = 10$ T.

For low effort and long life the hand hoists are popular in production and repair operations. Their small size is quite economic. For holding the load in any lifted position ratchet works as brake. The hoist block can be conveniently mounted on a trolley to have horizontal movement.

8.7.2 Electric Chain Hoist

In this hoist the hand operated chain is replaced by an electric motor. The mechanism is very much like the one shown in Figure 8.6. It is a closed unit inside a steel cover from which lifting chain hangs out along with electric motor control switch box. The body of the hoist can be hanged with a hook placed in the line of CG. Oil bath is provided for cooling of motor. Air motors of rotary and reciprocating types are also used in some designs. The reciprocating motors can start easily and are easy to control while lifting and lowering the load. In electric motor, braking is done in two ways. One way is to have current cut off to activate disc brakes while lowering the load. The other method is to have motor work as generator when lowering of the load reverses direction of rotation. The current generated is fed into circuit and the motion is controlled.

Both electric chain hoist and hand operated hoist can be run on overhead rails. In such case the electric hoist can be either carried on a monorail and the carriage can be pulled by an independent chain attached to the carriage or it can be attached to a platform running on two parallel tracks at proper elevation. An operator's cabin may be suspended at one side of the platforms.

A monorail carriage runs over four wheels, two on each side of the inside of an I-section which is secured to roof from top. Figure 8.8 shows schematically a monorail and Figure 8.9 shows an overhead platform crane.

Monorail carriages are used in different dimensions for load capacity of 1/2 to 10 T. The I-section sizes from 122.5 mm to 588 mm are used. The wheel tread diameter varies from 85.75 mm to 203.4 mm. The weight of the carriage may vary from 72 kgf to 625 kgf.

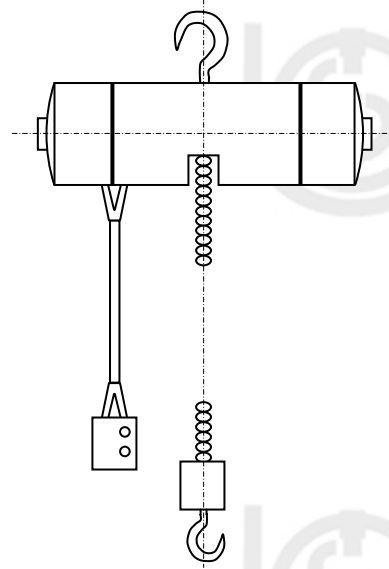

Figure 8.7 : Electric Chain Hoist

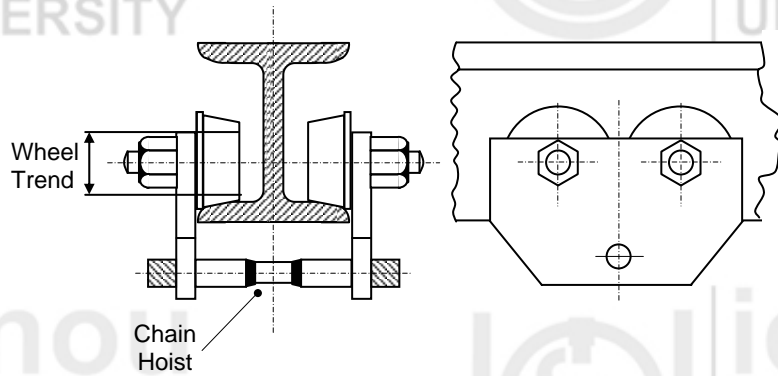

Figure 8.8 : Monorail for Electrical Chain Hoist

In an overhead crane, a platform spans over entire width of a shed or distance between two rows of columns. The platform is supported on wheels which move on I-section beams parallel to each other at considerable distance. The platform section may be designed for proper strength to carry its own weight, weight of an I-beam to serve as monorail, weight of electrical chain hoist and the weight to be lifted. Thus, the load can have motion up and down, (y-axis), from left to right (x-axis) and in direction perpendicular to plane of the paper (z-axis). For left to right (and vice-versa) motion the chain hoist may be pulled or a motor derive may be used. Similarly, for z-axis motion chain on the sprocket may be pulled manually or run by a motor.

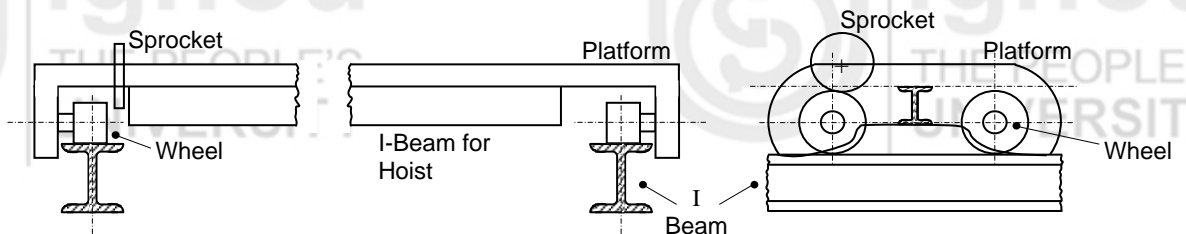

Figure 8.9 : An Overhead Crane

For load capacity greater than 50 T all drives are motor driven. Though in some cases where hazards exist (like chemical plants) pneumatic motors are used, yet electric motors of DC (series wound) and AC (squirrel cage) are preferred.

Variable frequency drives give good control over speed. Controls and limit switches are essentially installed.

For heavy loads the box girders are designed to span over the width. One of the four wheels is powered by electric motor through a gear drive. The crane of this type renders well for computer control.

8.7.3 Gantry Cranes

Gantry cranes provide an alternative to overhead crane for outside construction. In its simplest form, it is a beam supported over two columns which are carried over wheels. The beam carries all those arrangement as carried in the platform of an over head crane. For motion in the Z-direction the wheels are powered for which power can be drawn from electric motor through long shafts and bevel gears. Figure 8.10 shows the scheme of a gantry crane.

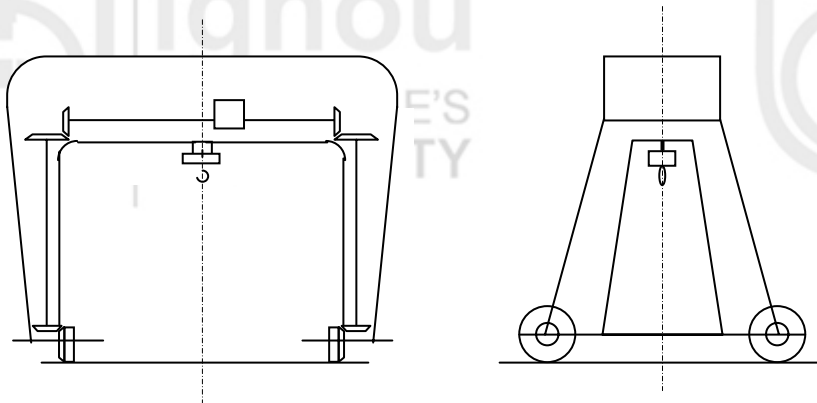

Figure 8.10 : A Gantry Crane Shown Schematically

Note the structure of the top beam and see that the span is adjustable. The smaller gantry can be manually pushed on the ground and can carry a hand pulled hoist. In smaller construction sites and shop floor, a gantry crane is much helpful.

8.8 ROTARY CRANES OR DERRICKS

These cranes differ in basic structure in that their main stay is a column which is also sometimes called mast or post. A boom stretches perpendicular to the column like a cantilever. The cantilever may have a sliding pair with the column or a pivot joint. In case of the pivot joint, the rope holds the boom which is often called jib. Several designs of this type of crane are in use for the purposes of lifting small weights on shop floor to heavy beams and blocks in the construction. These designs offer one advantage that their base being small in area, the crane can be erected on any mobile platform as truck or locomotive. The base can be rotated by putting it on a pivot. The lifting can be controlled from the base and hence the weight of the hoist is not to be borne by the crane structure.

In tower crane a cross member is pivoted on top. At one end of this member a balancing mass is placed which helps reduce the lifting effort considerably. Another advantage of the system is that the length of the tower can be increased which is an added advantage. The tower can even provide lift passage in which people and material can travel. The beam can rotate about its pivot support.

In Figure 8.11(a) and (d), a tower crane and a mobile crane on a truck is shown respectively.

A jib crane can be seen in Figure 8.11(c). In such cranes, the vertical post is provided with stay supports and jib is pivoted at the base of the vertical post. For

small vertical lifts of load jacks are often used. They may be screw jacks or hydraulic. Such jacks are used to lower the beam from gantry.

The mobile cranes are trucks, railway carriages or tracked vehicles. Figure 8.11(d) shows only one type of crane. The other crane often mounted may be rigid beam type which is used to tow the automobiles. Fork lifters which can lift the packets and packages can run on level surfaces. These are vehicles powered by IC engines or battery and used for material transportations in factories and warehouses.

Earth moving machines mounted on traction vehicles or wheeled vehicles are used for excavating, lifting and dumping the earth soil within a radius of a few meters. Their lifting mechanism which exerts force in both the direction may be hydraulically or mechanically operated. They, however, are also the examples of cranes.

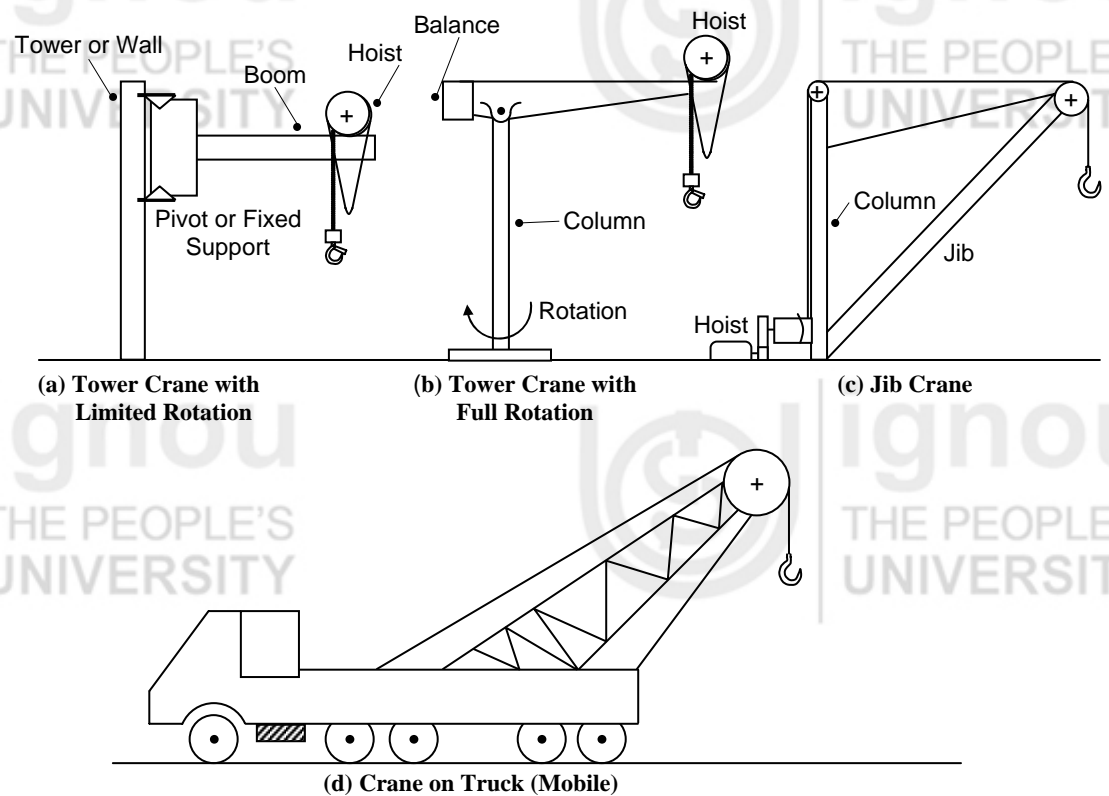

Figure 8.11

SAQ 1



- What is a lift? Where it is used? Explain the principle of lift operation.
- How do you classify the lift?
- Distinguish between a lift and an escalator.
- What is the principle of load lifting? Define mechanical advantage and velocity ratio. Give examples where cranes are used.
- Describe with sketch a few mechanisms used for lifting the load. Taking the example of a gear train show how it will satisfy the principle of load lifting.

- (f) Describe an electric chain hoist. How can this hoist be used to move the load along the length of workshop?
- (g) What is an overhead crane? Show its construction by sketch.
- (h) Describe a gantry crane and its usage.
- (i) What are rotary cranes? What are their applications?

8.9 SUMMARY

Movement of people up and down in tall buildings or even in not too tall building is a problem for which lifts are used. Lifts are box like cubicles which are moved in a dedicated well along the height of the building. They are operated through electricity and electrical motors are used as prime movers. All safety devices like locking them on rails and raising of alarm in case of sudden stoppage are employed. The lifts are classified on the basis of number of persons they can carry as well as on the basis of average speed with which they move. All lifts are supported side ways and cables hold them at the top for lifting and lowering. Counterbalancing mass is provided on parallel rails which effects in less energy use and reduction of jerks and vibration.

Lifting and shifting of weights and heavy bodies is a common problem encountered in industry and during construction. Cranes of various types are used for lifting the load. Cranes are essentially made of two units. One is meant for lifting action which can be called a hoist other is structure which provides support to load and the hoist. Depending upon type of structure the load can be moved in horizontal plane in lifted condition.

Several types of crane are in use. Overhead cranes normally form a movable platform on wheels and rails above the ground level. There may be a single rail or two rails on which structure supporting the hoist runs. The crane can be pulled by chain or rope from the ground or can have an electric motor. The gantry crane is a beam across two supports. These carry the lifting hoist which can move along the length of the beam. The whole gantry can move on wheels over the ground. The gantry can be pushed manually or powered by electrical motor through gearing. Rotating cranes or derricks contain a column or a mast which supports a beam in horizontal plane at a height or a jib pivoted at the base of the mast. The hoist is provided at appropriate position either at the base or on the beam. The force is transmitted through the wire ropes running on grooved pulleys and winding on drums. Similar cranes can also be placed on moving platforms of trucks or railway wagon.

The cranes are most important equipment in building and bridge construction, moving of earth and also in industry.

8.10 ANSWERS TO SAQs

SAQ 1

- (e) The gear train is shown in Figure 8.12.

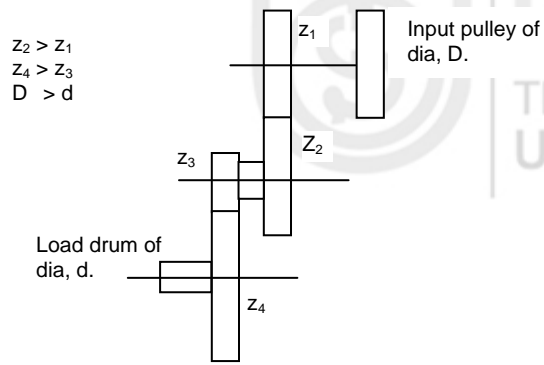

Figure 8.12

Z_1, Z_2, Z_3 and Z_4 are number of teeth. For one rotation of input pulley effort E will move through πD and output shaft will move $\frac{Z_1 Z_3}{Z_2 Z_4}$

rotation. Hence, load is lifted through $\frac{Z_1 Z_3}{Z_2 Z_4} \pi d$

$$\therefore VR = \frac{Z_2 Z_4}{Z_1 Z_3} \frac{D}{d}$$

FURTHER READING

Chakraborti, A., *Circuit Theory*, Dhanpat Rai Publications, New Delhi.

Fowler, Richard J., *Electricity*, International Edition, Tata McGraw-Hill Publishing Co. Ltd., New Delhi.

Del, Toro V., *Principles of Electrical Engineering*, Prentice-Hall of India, New Delhi.

Rajput, R. K., *Basic Mechanical Engineering*, Laxmi Publications, New Delhi.

Bansal, R. K., *Mechanical Engineering*, Laxmi Publications, New Delhi.





ignou
THE PEOPLE'S
UNIVERSITY



ignou
THE PEOPLE'S
UNIVERSITY



ignou
THE PEOPLE'S
UNIVERSITY



ignou
THE PEOPLE'S
UNIVERSITY



ignou
THE PEOPLE'S
UNIVERSITY



ignou
THE PEOPLE'S
UNIVERSITY



ignou
THE PEOPLE'S
UNIVERSITY



ignou
THE PEOPLE'S
UNIVERSITY



ignou
THE PEOPLE'S
UNIVERSITY



ignou
THE PEOPLE'S
UNIVERSITY

E/M ENGINEERING

This course on E/M Engineering (Electrical/Mechanical Engineering) deals with the basic concepts of electrical and mechanical engineering and their elementary applications which is very important for the learners of every branch of engineering. The fundamentals of E/M Engineering taught in this course will help you in planning and execution of any engineering project.

The course consists of eight units. First four units deal with the fundamentals of Electrical Engineering while rest of the four units cover the key features of Mechanical Engineering.

Electricity is an important source of energy in the modern times. It is used in our homes as well as in industries. For example, electricity is used in our homes for lighting, operating fans and heating purposes. In industries, it is used to operate various types of machine. In Unit 1, you will be introduced with the technical aspects of electricity while discussing the fundamentals of electricity.

Unit 2 discusses electromagnetism, electrostatics and electrical instruments. In this unit, you will study the laws of electrostatics giving the details of static electricity with importance of capacitors in storage of energy. The unit also covers the basic fundamentals of electromagnetism and electrical instruments.

So far, you have studied DC circuits. The primary source of emf in such circuits is a battery and the basic circuit element is an ohmic resistance (R) which controls the current (I) as per Ohm's law $V = IR$. But most of the electric power generated and used in the world is in the form of AC, i.e. alternating current. The electric current whose magnitude changes with time and the direction reverses periodically is known as alternating current. Similarly, the emf (or voltage), whose magnitude changes with time and the direction reverses periodically is known as alternating emf. In Unit 3, you will learn the basics of AC circuits.

You will be introduced to the electrical machines in Unit 4. In this unit, you will understand the principles of operation of DC machines, the working and types of DC motor and generators.

Unit 5 discusses the units of measurement, gas laws and fuels. Measurement is an essential part in the field of engineering and technology. In this unit, you will understand the basic units of measurement. Thermodynamic systems, gas laws, laws of thermodynamics, energy conversion cycles and fuels have also been discussed in this unit.

Heat engine is an energy conversion device in which heat energy is converted into the mechanical energy. Heat engines are generally classified as internal combustion engines and external combustion engines, by the manner in which combustion of fuel takes place either inside the combustion chamber or in a separate unit placed outside respectively. Internal combustion engine is, therefore, a heat engine in which combustion of the fuel takes place inside the cylinder.

Unit 6 introduces the different aspects of internal combustion engine.

We all know from our day-to-day experience that heat flows in the direction of decreasing temperature, i.e. from high temperature region to low temperature region. This heat transfer process occurs in nature without requiring any device. The reverse process, however, cannot occur by itself. The transfer of heat from a low temperature region to a high temperature region requires a special device called refrigerator. The process of conditioning the surrounding air according to the human comfort and desire is called as air-conditioning. Air-conditioning does

not mean only the control of the temperature but also the control of humidity, oxygen content and air movement. Unit 7 discusses the working principles of power absorbing system such as refrigeration and air-conditioning system.

In most of the industries, you must have seen the lifts and cranes. A lifting machine is a device which enables to lift a heavy load by applying a comparatively small effort. Crane is a versatile and most useful lifting machine. It enables to perform the operation with speed, safety and precision. It is necessary to know the lifting capacity and working range of a crane to be selected to perform a particular given job. Unit 8, the last unit of this course, describes the different features of lifts and crane along with other technical parameters.

The Self Assessment Questions (SAQs) given in the units are intended to help you in verifying whether you have grasped the presentation and provides the needed feedback about your progress. You are advised to study the text carefully. Try to solve the SAQs on your own and verify your answers with those given at the end of each unit. This will definitely develop your confidence.

At the end, we wish you all the best for your all educational endeavours.



ignou
THE PEOPLE'S
UNIVERSITY



ignou
THE PEOPLE'S
UNIVERSITY



ignou
THE PEOPLE'S
UNIVERSITY



ignou
THE PEOPLE'S
UNIVERSITY



ignou
THE PEOPLE'S
UNIVERSITY



ignou
THE PEOPLE'S
UNIVERSITY